Specifications

Tubing

44.5mm O.D. Frame Legs / Rails

51mm O.D. Frame collars

Platforms

Light Duty 1 man S.W.L. 125 kg

Heavy Duty 2 man S.W.L. 325 kg

Towers comply with:

A.S./N.Z.S.157 A.S.1170 A.S./N.Z.S.4576

Registered with Workcover Authority, **V974086**.
Occupational Health & Safety Division

Tested and approved by **N.A.T.A.**

The following Organisations were instrumental in preparing the Australian and New Zealand Standards to which **Hi-STAGE** Towers are manufactured;

A.C.T. Workcover.

Health and Safety Organisation, Vic.

Workcover Authority N.S.W.

Work Health Authority N.T.

Dept. of Occ. Health, Safety, and Welfare W.A.

Dept. of Employment and industrial relations Qld.

Dept. Labour New Zealand.

SAFETY NOTES

- 1 Only move a mobile tower by pushing at the base
- 2 Never move a tower with a person or loose material on the platform.
- 3 Never climb up the outside of a tower.
- 4 Never use a tower without plates, or wheels fitted
- 5 Always erect tower on a suitable foundation (concrete or similar paving). When erecting on soil base, place feet on timber sole plates at least 250x250x50mm.
- 6 Always securely tie to a static structure at 2400. intervals all towers that exceed 4M. platform height.
- 7 Do not overload the platform
- 8 A stationary tower must be dismantled before moving
- 9 Never lean a ladder against an unsecure tower.
- 10 Do not impose excessive sideways forces while working, pushing from the tower.

Hi-STAGE
P: 03 5962 1133
E: sales@yunckens.com.au
W: yunckens.com.au
21 Harker St,
Healesville. VIC 3777

ASSEMBLY INSTRUCTIONS

Rossi Roller Doorway Tower

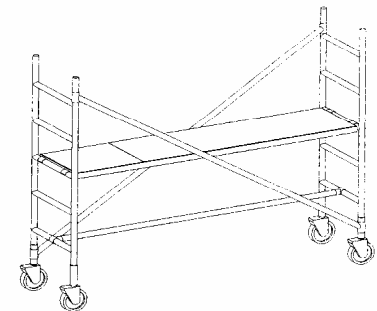

Hi-STAGE systems

Lightweight Mobile
Scaffold Towers

THINK SAFETY

WORK SAFELY

Assembly Instructions

- 1 **Read Safety Notes**
- 2 Hold 1 end Frame upright in position and fit the 2 Diagonal Braces (Red collar) over the top of the leg tubes. Position the Braces evenly apart and Allow the lower end (Black) to rest on the ground.
- 3 Stand the second End Frame in to the lower sockets (Black) of the previously positioned Diagonal Braces .
- 4 Tighten 'J' bolts on both lower Black collars.
- 5 Position the 2.4 Clip Rail to either the top or bottom of the End Frames according to the platform position required. (see diagrams).
- 6 Fit Platform
- 7 Fit Castors into End Frames and tighten lock nuts.
- 8 **Optional Guard Rails/ Kickboards**
- 9 **Fit the two 1 meter tall additional frames on to the top of each end frame. Ensure it is fully seated and tighten the J bolts.**
- 10 **Fit the 2400 Hand Rails in to position over the top of the End Frame legs.**
- 11 **Fit the 2400 Clip on (Mid) Rails in to position midway between the Hand Rail and the Platform**
- 12 **Install the Kickboards around the edge of the Platform**

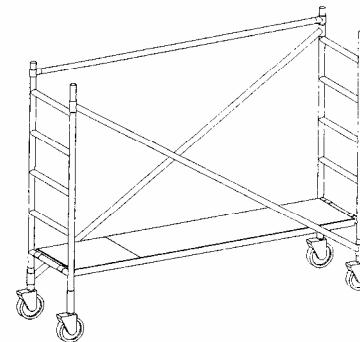
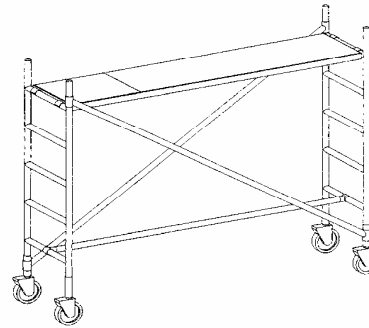

KIT includes:- 2 End Frames, 2 Diagonal Braces, 1 Clip Rail, 1 Platform, and 4 Castors

In line with our policy of continuous development we reserve the right to alter specification without prior notice

Please be aware that to comply with **A.S./N.Z.S. 4576:1995** Where platform heights exceed 4 metres (5 metres New Zealand) a certificate of competency would be required by person in charge of erection

•Regularly inspect tube ends and platform boards for damage or deformation and dress accordingly.

All towers are produced to specification and certain principles of construction that fall within present Standards. When towers are used for commercial purposes the Health and Safety at Work Act and Construction Workplace Regulations must be observed